

GSO - GVSO

Horizontal Bran Finisher

Machine designed to perform the sieving process with products characterized by poor flowing. By taking advantage of an air intake, the product is facilitated to reach the sieving mantel where, thanks to a series of adjustable breaking paddles, the sieving process is optimized.

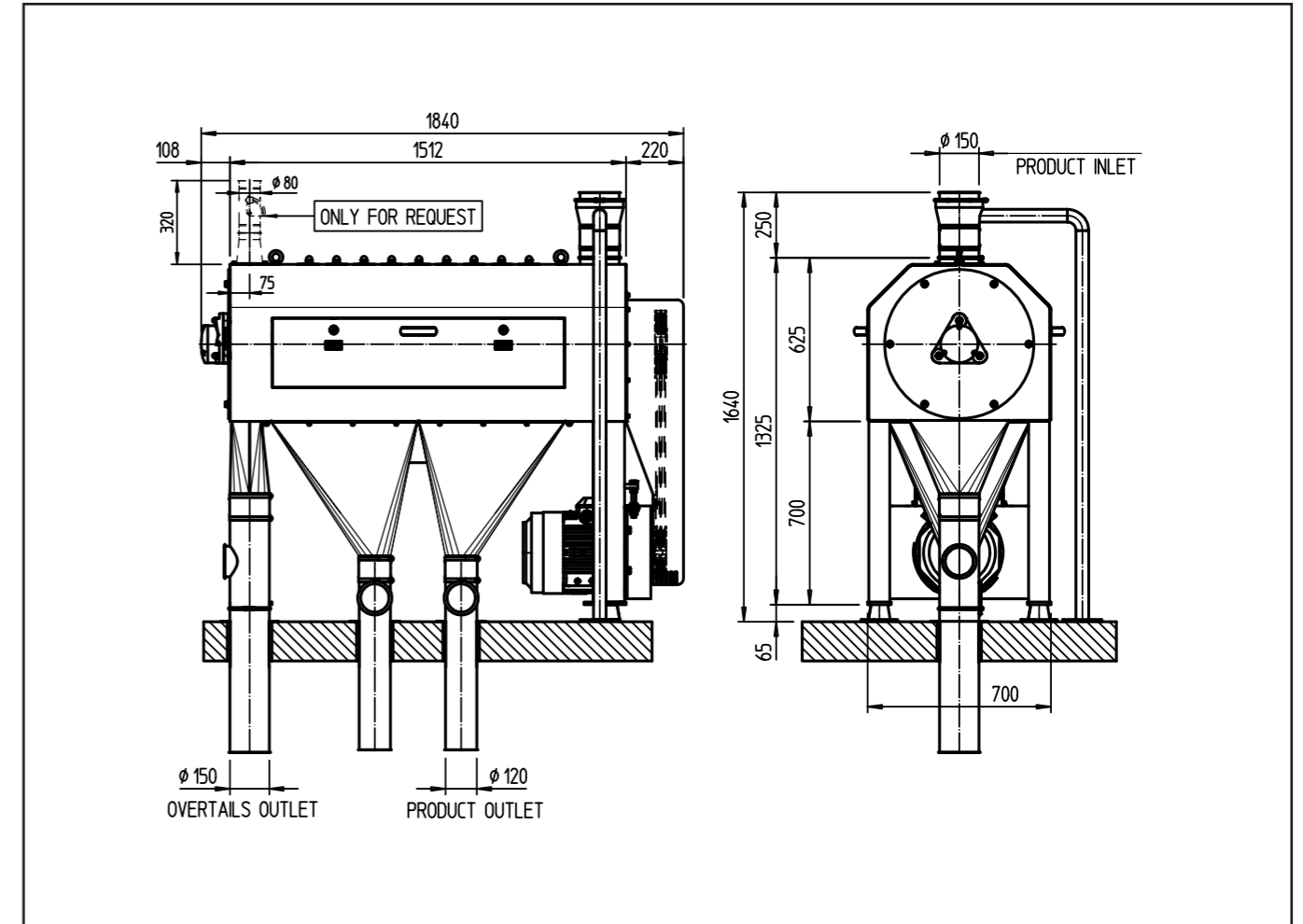

Model	*Capacity t/h	Motor kw	Sifting Surface m ²	RPM	Aspiration m ² /l' mm H ₂ O		Weight kg	Volume m ²
GSO/V-5012A	1.5 - 2	7.5	1.1	1100	5	80	420	2.3
	3 - 4	11						
RFP-C-5	1	5.5	1.1	1100	5	80	420	2.3

Units = mm