

# MOV

## Quick mixer

The Quick Mixer performs the mixing of products reducing significantly the mixing time, guaranteeing an optimal homogenization of the blends.

The special geometrical shape of the mixing chamber enables a significant reduction of working times and a perfect mixing in just 1.5 minutes with an accuracy of 1:100,000.

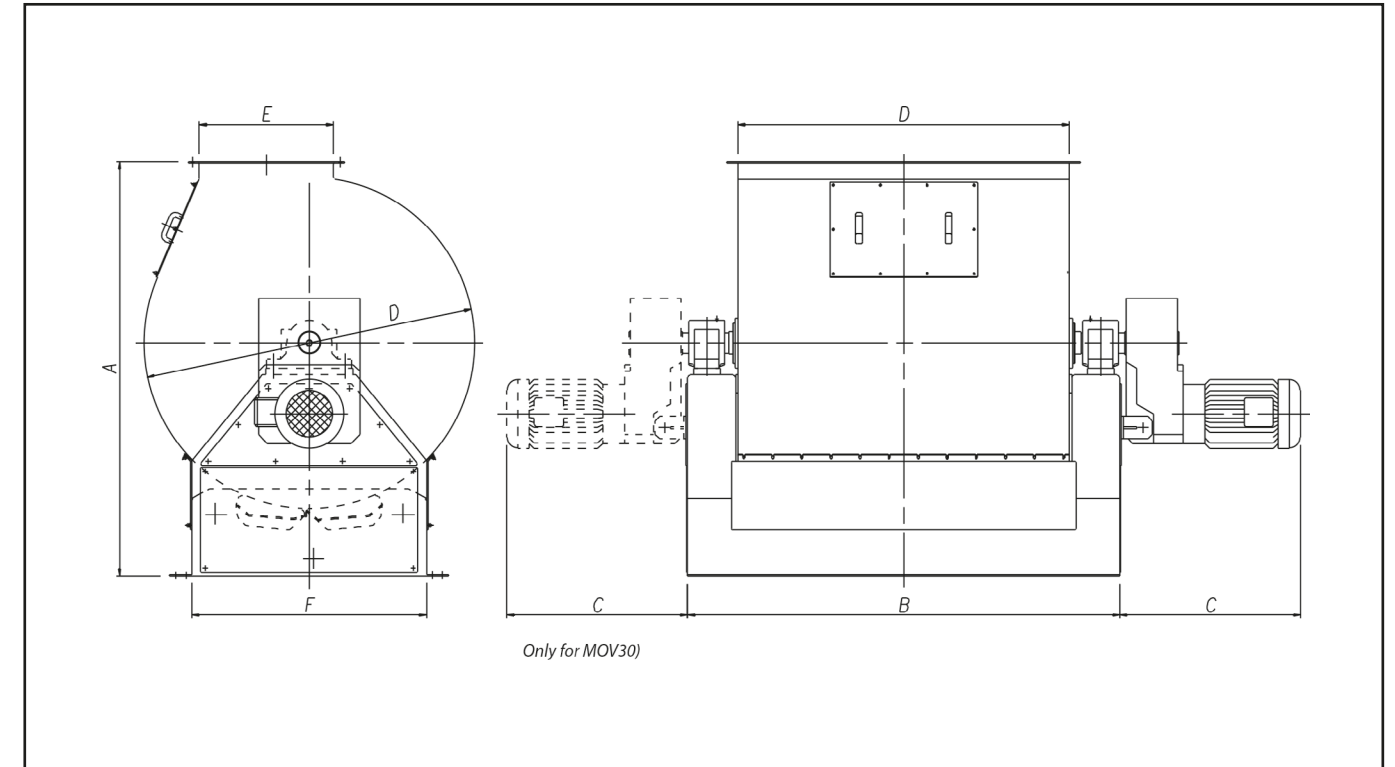
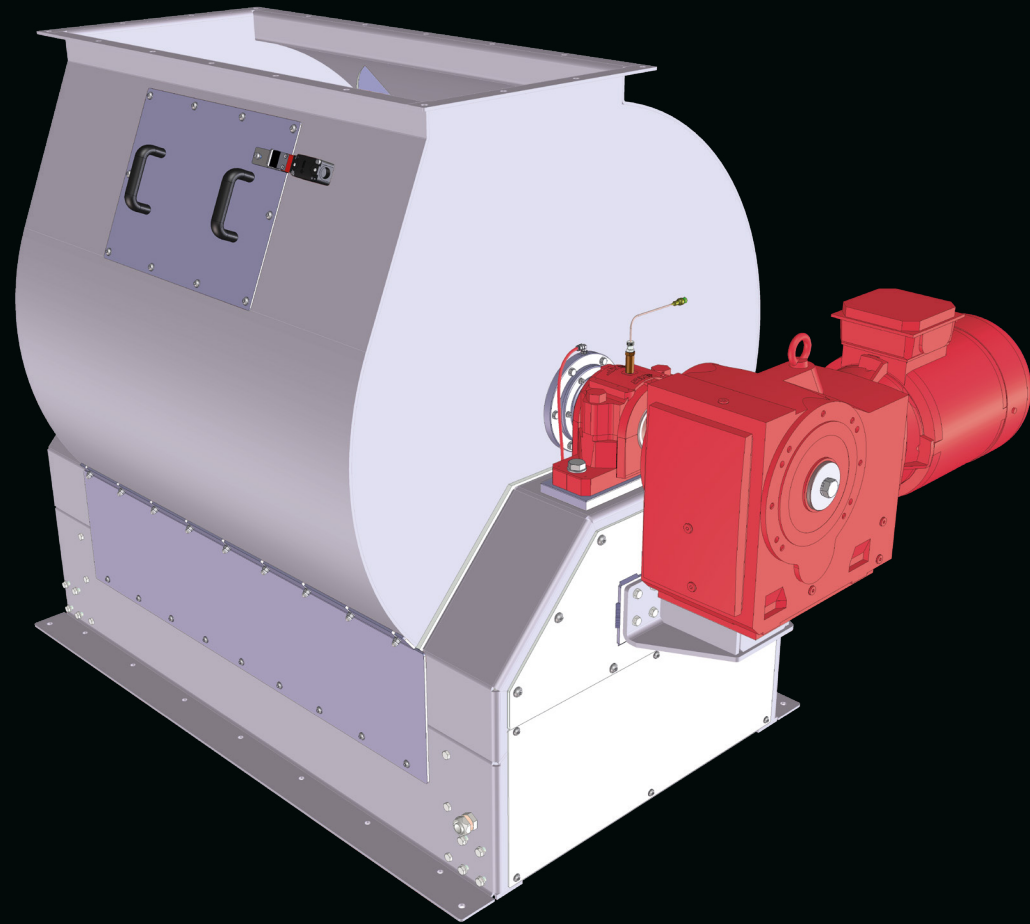

Model	A	B	C	D	E	F	Power kW	Rev./min R.P.M	Volume Lt	Weight Kg
MOV 5	1500	1620	900	1180	500	900	15	62	1000	1480
MOV 10	1850	1930	1050	1480	600	1026	22	50	2000	1900
MOV 20	2350	2450	1150	1860	750	1320	45	40	4000	3400
MOV 30	2700	2800	1050	2140	850	1550	30+30	35	6000	4700

Units = mm