

MS 60

Hammer Mill

Reversible rotation machine controlled by means of an electric motor. It features a metal construction with gauge broadly dimensioned. The rotor is dynamically balanced and equipped with special profile hammers in hardened steel. Machine complete of base for the fastening of the electric motor.

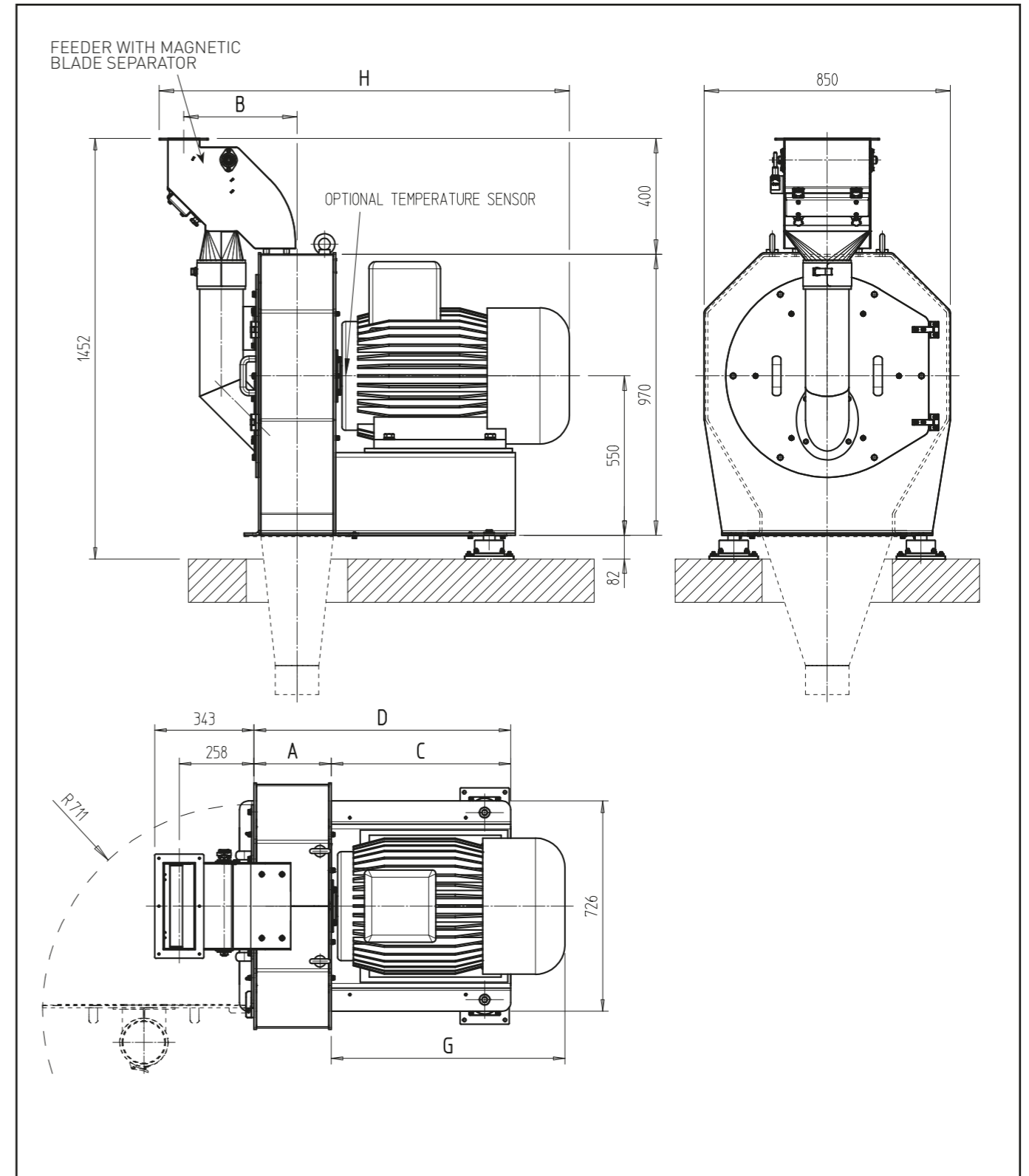
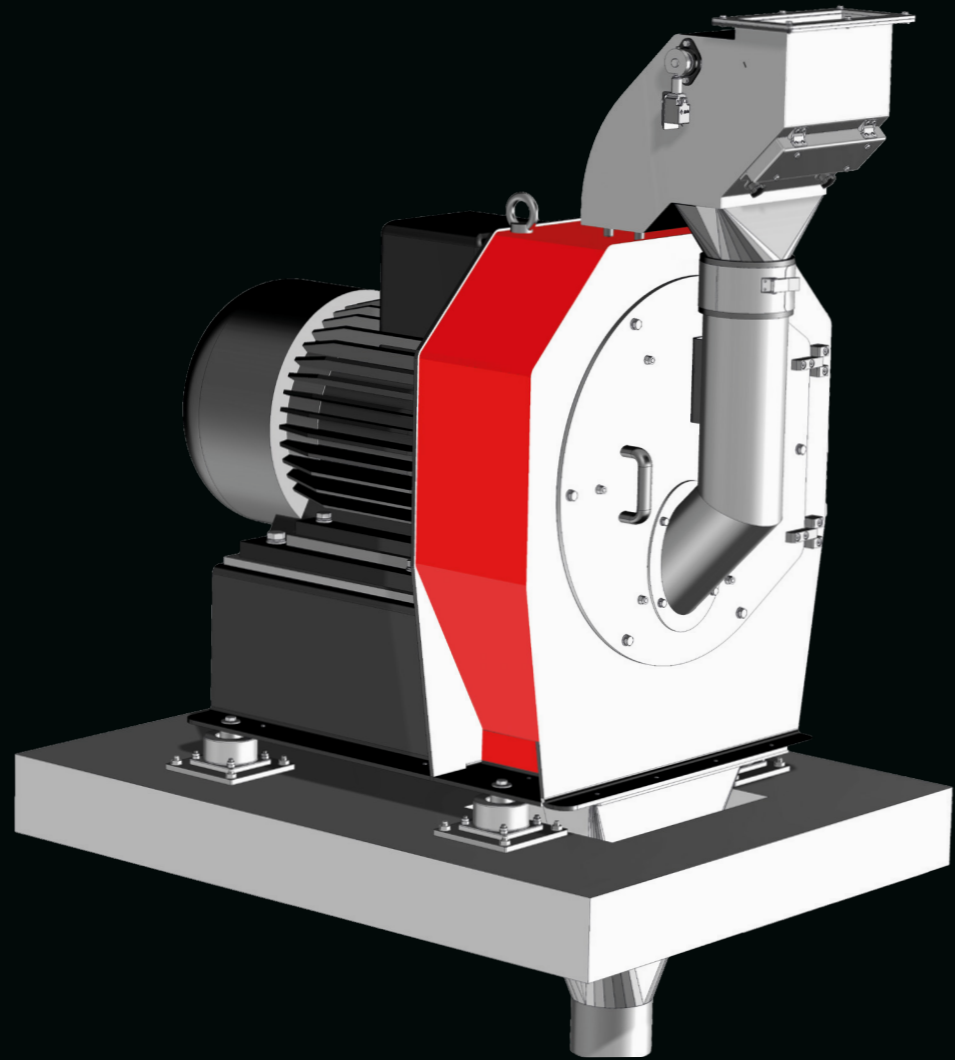

Model	Hammer N°	Capacity max t/h	Motor Kw	Aspiration m3/1'	A	B	C	D	G	H	Weight Kg	Volume m ³
MS 60/19	24	varies according to product	15	15	206	361	544	750	507	1056	500	1.36
			22						577	1126	550	1.4
MS 60/25	40	varies according to product	30	15	266	391	620	886	677	1286	670	1.6
			55						807	1416	790	1.8

Units = mm