

# MSB

## Hammer Mill

Reversible rotation machine controlled by means of an electric motor. It features a metal construction with gauge broadly dimensioned. The rotor is dynamically balanced and equipped with special profile hammers in hardened steel. Machine complete of base for the fastening of the electric motor.

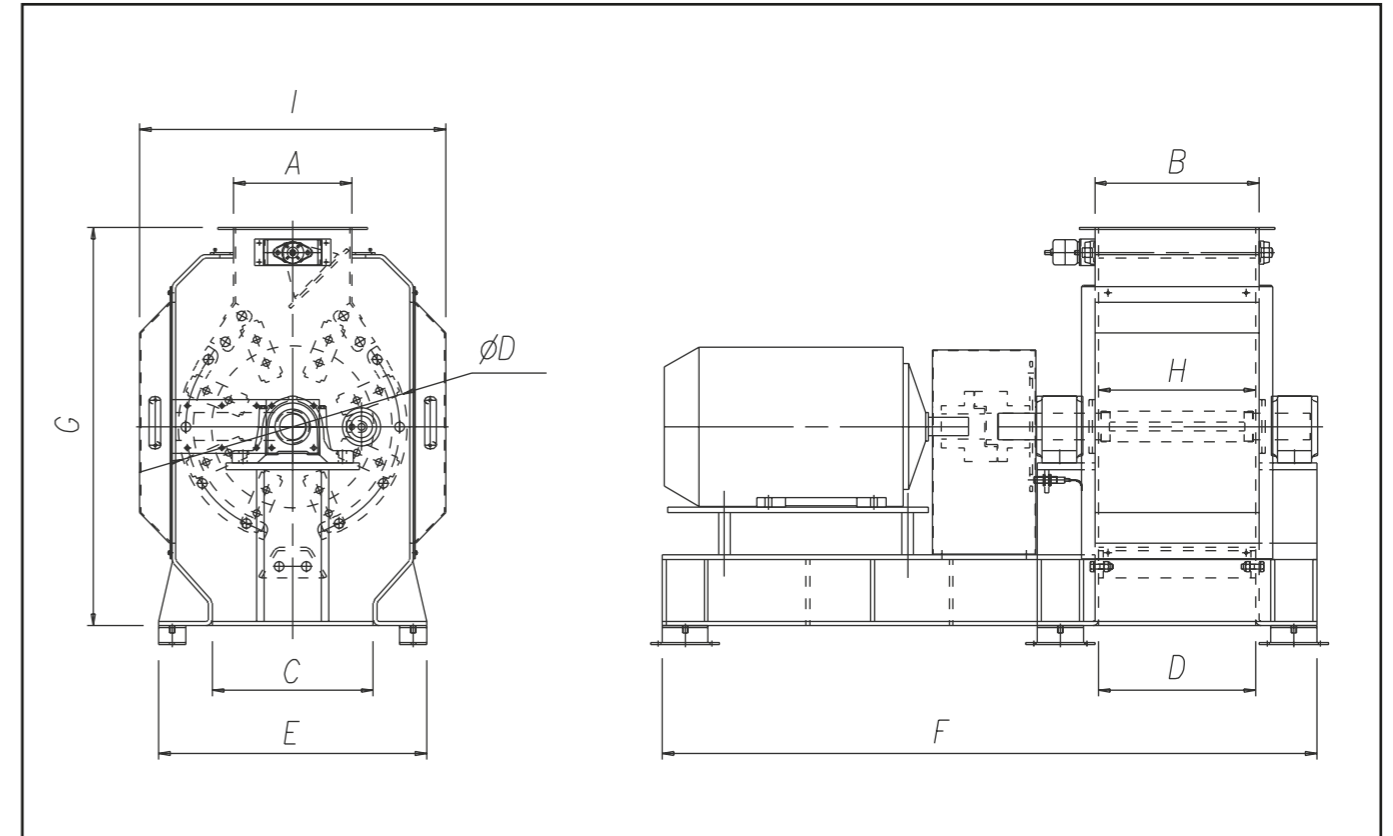

Model	Motor kW	A	B	C	D	E	F	G	H	I	ØD
MSB 60/40	30÷55	310	430	420	410	700	1710	1040	355	800	600
MSB 60/60	30÷75		620	420	600	700	1900	1040	545	800	600
MSB 60/80	75÷132		810	420	790	700	2210	1040	735	800	600
MSB 60/100	110÷200		1000	420	980	700	2400	1040	925	800	600

Units = mm