

POND 12

Automatic Scale

The production automatic scale, POND 12 type, allows for the weighing of granular and floury products with a range varying from 12 to 270 m³/h. The machine features a loading hopper, a gravity feeder, a weighing container and a dumping hopper. An electro pneumatically regulated bucket slide valve, positioned at the entrance hopper, regulates the flow of product to the tubular weighing system which, suspended on load cells system, determines the weight with an accurate and stable method. The machine is equipped to manage products both with poor and good flow.

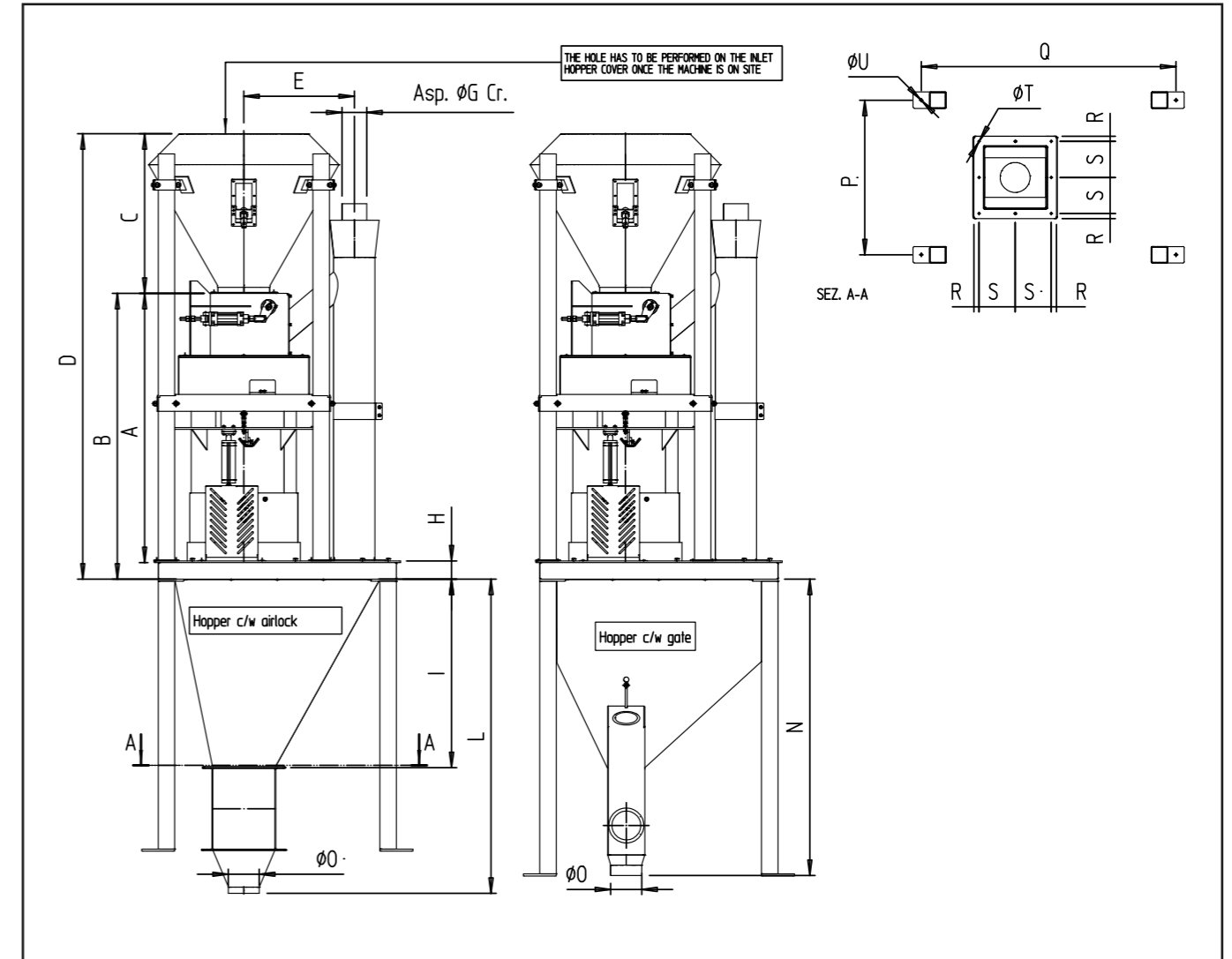

Type	Max output m ³ /h	Air consumption NI/6 bar cycle	Aspiration m ³ /1'
POND 50	15	6	5
POND 100-A	31	7	8
POND 200	53	8	10
POND 300	90	9	12

Type	A	B	C	D	E	F	G	H	I	L	P	Q	R	S	T	U
POND 50	1176	1246	660	1906	420		100	78	573	1093	452	832		150		
POND 100-A	1306	1386	775	1306	536	340	120	88	914,5	1330	750	1155	25	150 175	9	13
POND 200	1806	1886	975	2861	580	565	120	88	1012	1460	750	1290	25	200	9	13
POND 300	1980	2060	1067,5	3127,5	590	577,5	150	88	1430	1430	750	1340	25	225	9	13

Units = mm