

ROTODIV

Diverter Valve for the transported product flow

Machine designed to perform a pressured pneumatic transport of powder products or products with low granulometry, guaranteeing no issues in the transport of the products thanks to its internal holdings which can support high pressure.

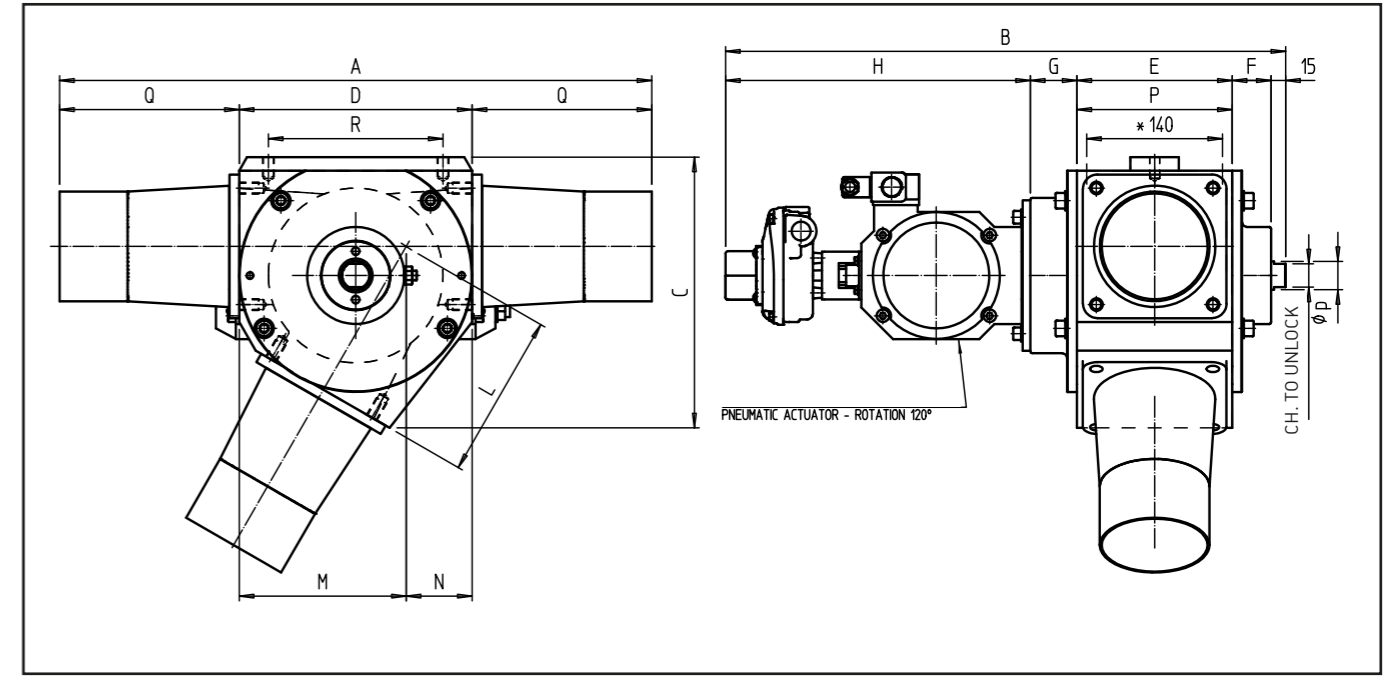

Model	A	B	C	D	E	F	G	H	L	M	N	P	Q	R	Weight Kg
Rotodiv Ø65	515	467	173	145	101	36	42	273	105	100	45	85	185	105-M8	36
Rotodiv Ø95	560	547	222	190	130	40	48	314	133	134	56	120	185	140-M10	40
Rotodiv Ø120	610	577	279	240	160	40	48	314	170	172	68	148	185	180-M12	56
Rotodiv Ø150	730	643	350	310	192	48	60	328	219	217	93	180	210	230-M16	96
Rotodiv Ø200	900	697	466	400	246	48	60	328	294	287	113	240	250	280-M16	172

Units = mm