

SD 71

Flour Detacher

Machine designed for the breaking of flour particles under its roller mills. It features a rotor with inclined bladed bars rotating at high revolutions and four beaters rotating at high speed. Moreover, impact panels are placed in the rotor's internal wall to improve the disintegration process.

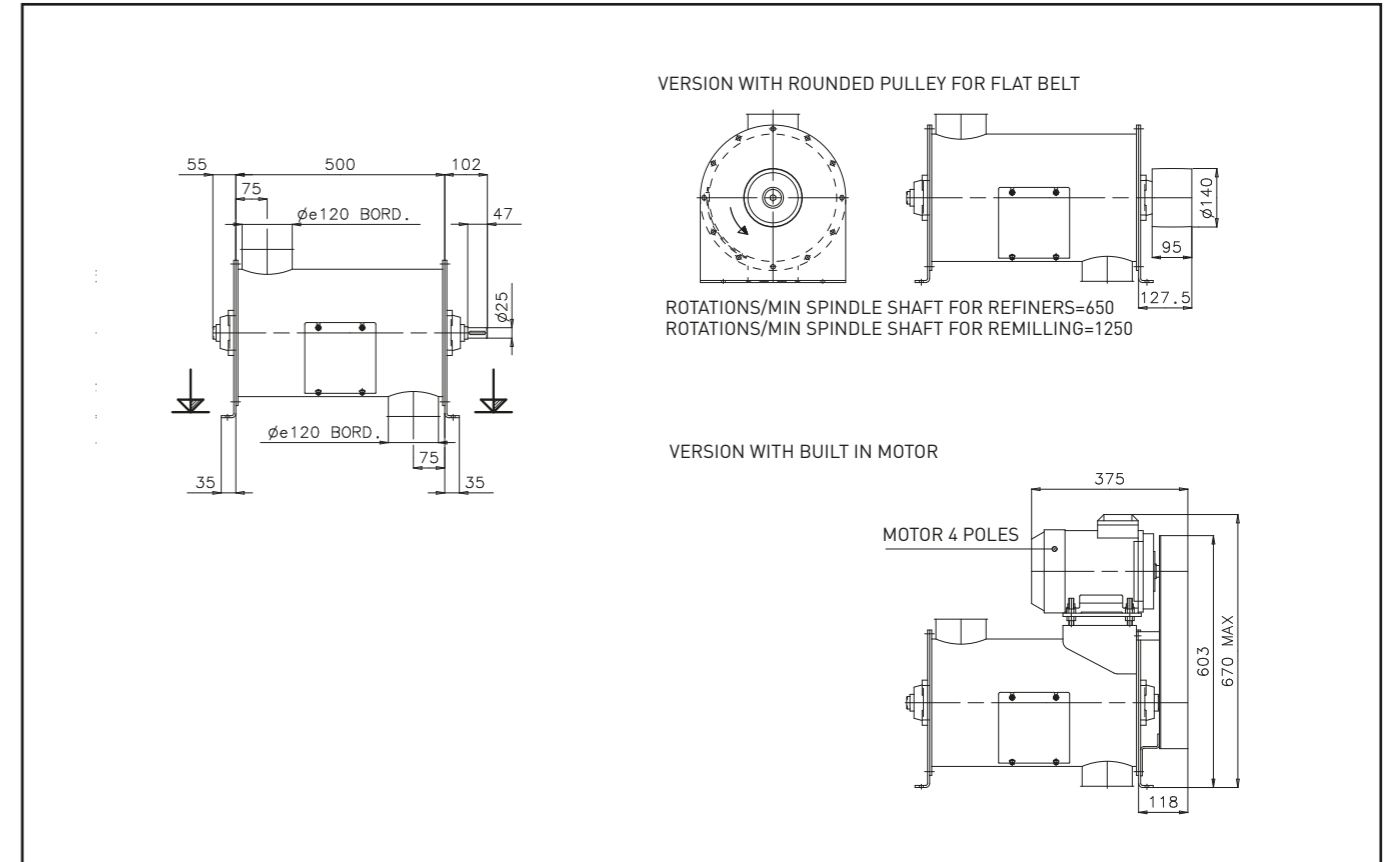

Type	Kw	Hz
SD/71-1,5	1,5	50
SD/71-2,2	2,2	50
SD/71-3	3	50
SD/71-1,5	1,5	60
SD/71-2,2	2,2	60
SD/71-3	3	60

Units = mm