

SPD/P

Pulversan Infestation Destroyer

Machine designed for the mechanical disinfection of insects and their eggs from floury products that need to be inserted in the pneumatic transport circuit.

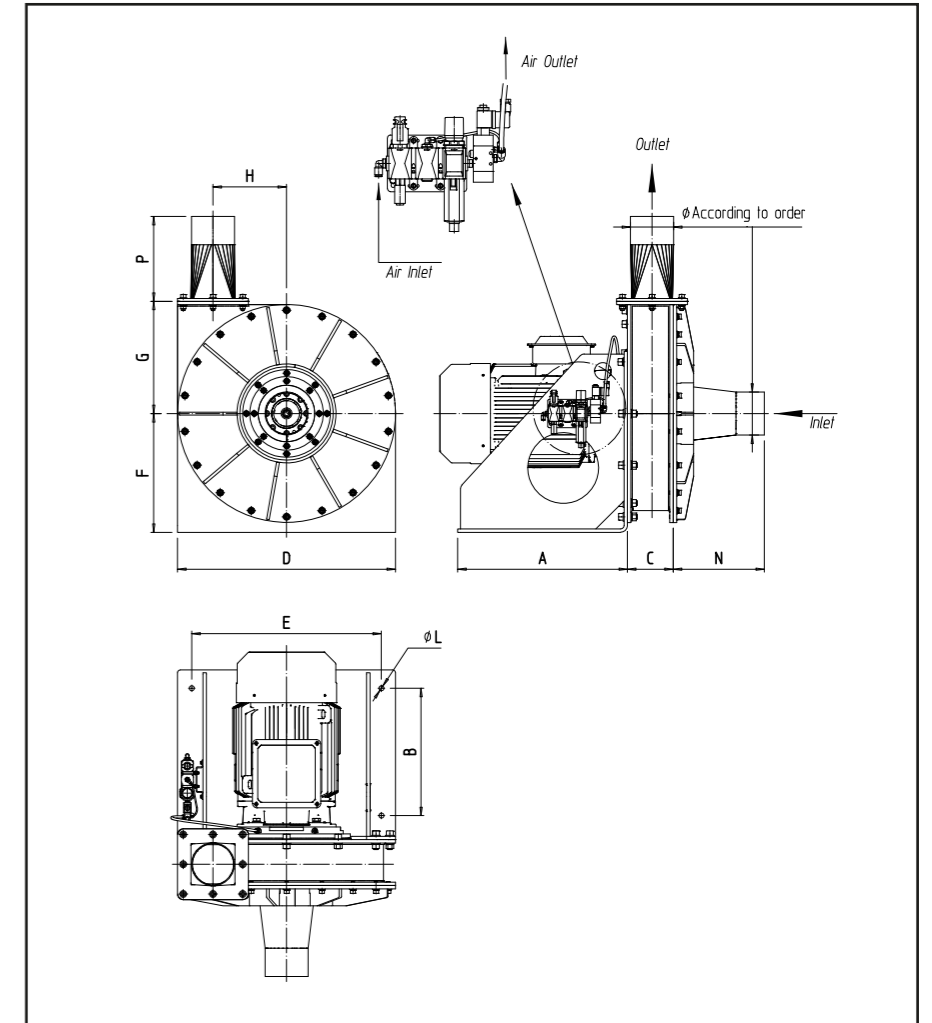

Model	Motor kw	Capacity (flour) T/H		A	B	C	D	E	F	G	H	ØL	N	P	Weight kg
		50Hz - 3000RPM	60Hz - 3600RPM												
SPD-P45	5.5	2	2.5	300	210	100	600	520	330	308	197	14	216	300	355
	7.5	3.5	4												380
	11	5.5	6												405
SPD-PS50C	18.5	8	6	600	450	162	770	670	420	397	260	18	322	300	485
	22	10	8												495
	30	12	9			510									
SPD-PS50C1	37	15	12	600	450	280	770	670	420	397	260	18	322	400	633
	45	20	15												695
	55	22	20												723

Units = mm