

TRF

Turbo Sifter

Machine particularly suitable for flour redressing before bagging, and it can be used as a cleaning waste selector. The TRF features a rotor composed of cast iron ray systems with shaped plates, equipped with palette and brushes alternatively arranged. Thanks to these, the rotor forces the product through the mesh.

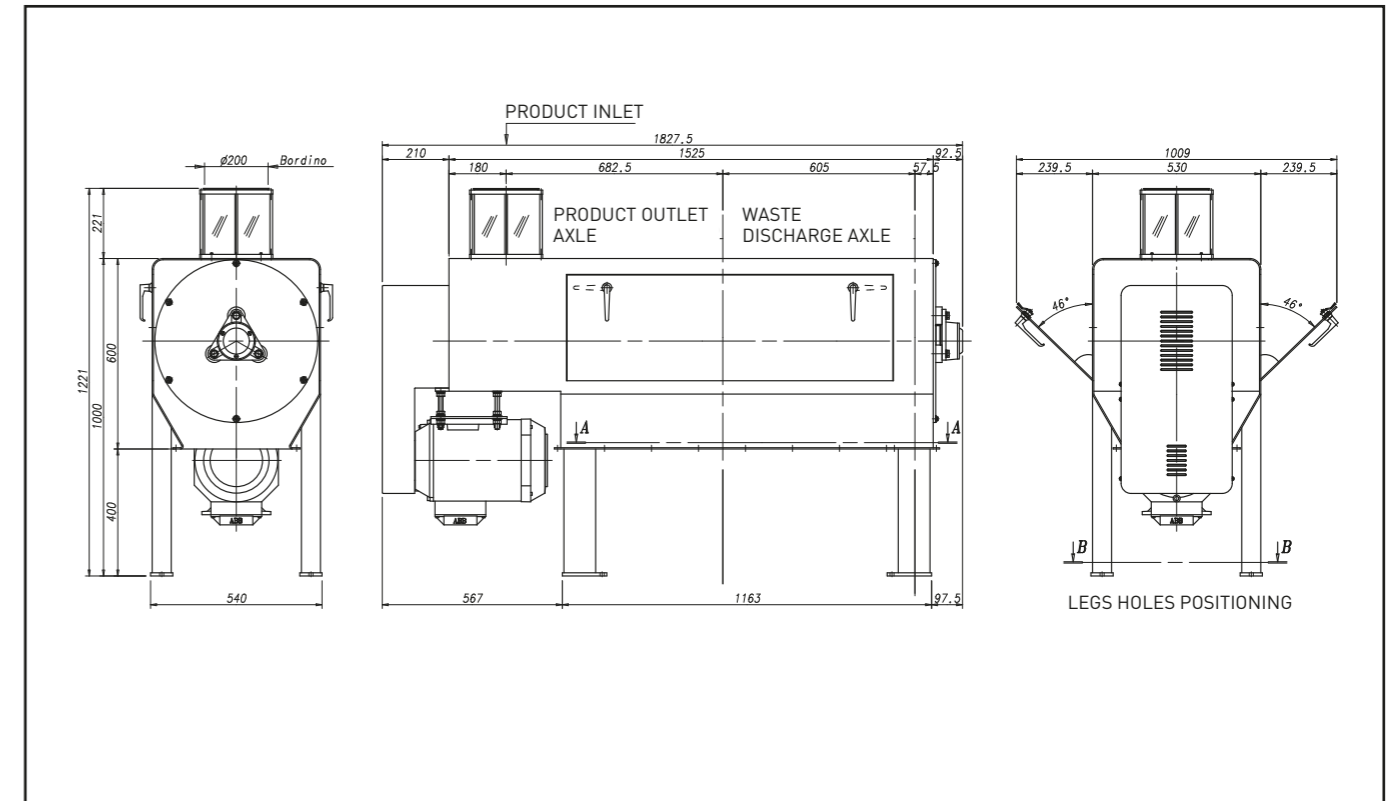
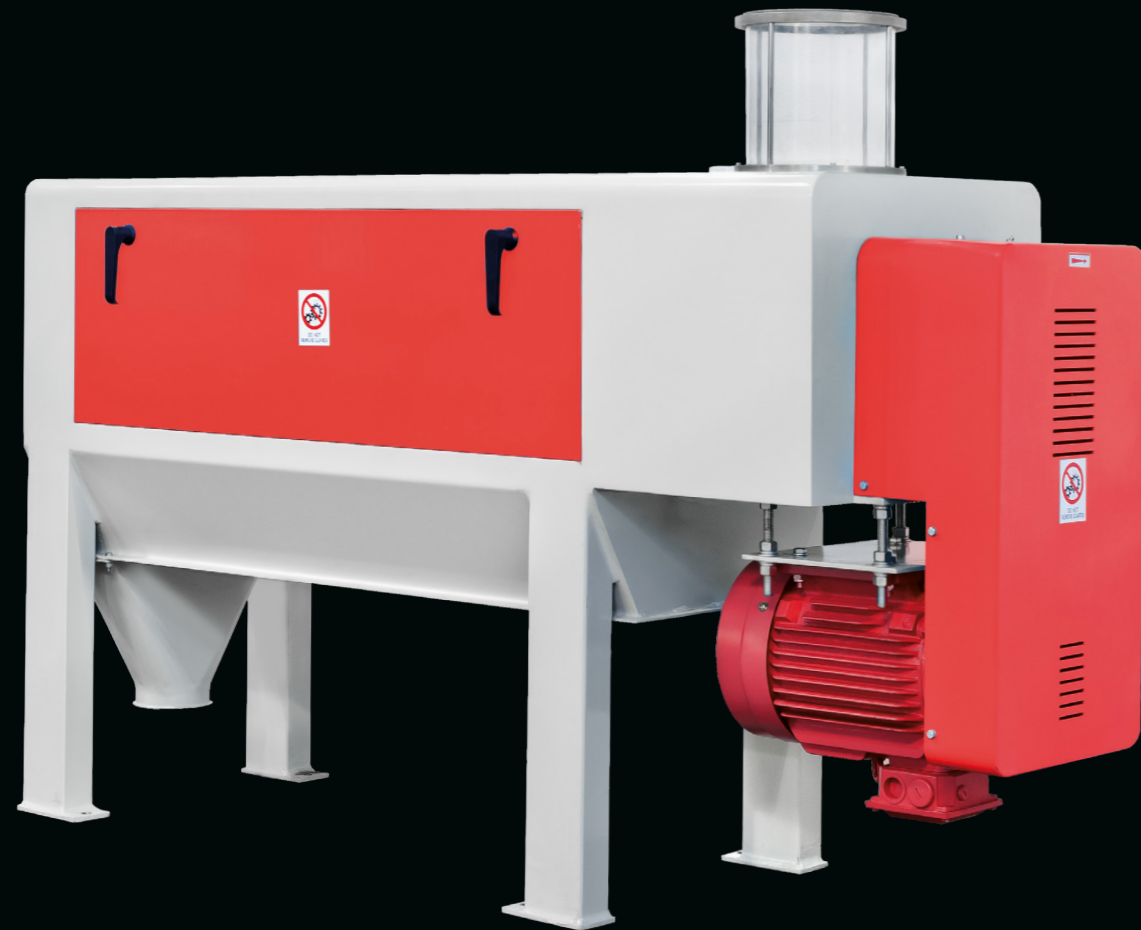

Type	Machine passage	Screen	Capacity t/h	kW	Weight Kg
TFR 40/100 - 5,5	Screenings cleaning	Metal sheet holes d. 3	20	5,5	318
TFR 40/100 - 7,5	Flour redressing	Metal sheet holes d. 3	40	7,5	325

Units = mm